

EWIKON

Valid for
item numbers:

69010.306 (6-zone)

69010.312 (12-zone)

69010.324 (24-zone)

69010.336 (36-zone)

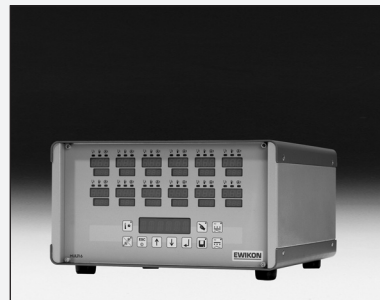
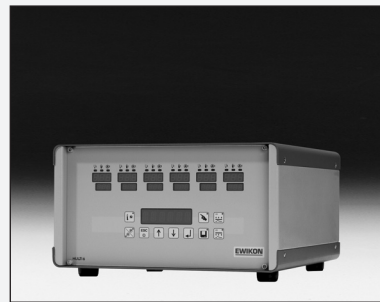

HPS-C-Multi 6 **Hotrunner controllers** **Operating manual**

Software version 1.12 or higher

EWIKON

Table of Contents

General

Safety instructions	4
Proper use	4
General instructions	4
Setup	5
Cleaning	5
Maintenance	5

Controller

Fault displays	6
Settings (Factory settings)	6
Commissioning	7
Front view	7
Entering setpoint value / Switching off control zones	8
Function keys	8
Changing setting values	9
Soft-start ramp	9
Manual mode	10
Mould memory	11
Replacing fuses	12

Connections

Load, thermocouple	13
Alarm plug	14

Technical data	14
--------------------------	----



**Important operating instructions,
to be followed at all times!**

Safety instructions



Please read these operating instructions through carefully before commissioning.



Work on the unit may be carried out only by qualified personnel.
Disconnect from the power supply before opening the housing.



Replace fuses only with the same type (see Replacing fuses).



Before connecting the tool cable, ensure that
all plugs are connected correctly (see Connections).



Check the power supply cable and tool cable regularly for damage.
Replace connection cables if the cable sheathing is damaged!



In case of faults, this can lead to increased temperatures at the connected heaters.
An external temperature protection device must therefore be provided to protect against over-heating.

Proper use

The HPS-C-Multi6 hotrunner controllers are industrial temperature regulators. They are designed for regulating temperatures of hotrunner moulds. The controllers record the temperature at the relevant zone by means of a thermocouple, and regulate the power output of the heating element accordingly.



The manufacturer accepts no liability for damages caused by improper use of the controllers.

General

A control zone is required for each heater to be connected.

A control zone consists of a thermocouple input and a load output with fuse.



Ensure correct allocation of the connections of the
mould cabling at all times (see Connections).



All unneeded control zones must be switched off.



Heat-resistant, braided cable must be used as the connection cable for the load current circuits.
A special compensating cable is required for the thermocouples!
Leads and cables are available as original accessories.

Setup

The controller must be set up on a firm and level surface, at a height where it is easy for the user to read the displays and operate the controller.

The controller is equipped with a built-in, high-performance fan, which prevents excess heating of the end-stage during operation. In the MULTI 6 24- and 36-zone controllers, the ventilation openings are located on the underside and rear of the controller. Take care to ensure that the air supply to these openings is never blocked or obstructed.

Cleaning

The outside of the controller and the operating panel can be cleaned with a soft cloth soaked in alcohol. Please do not use any abrasive cleaners or scouring agents.

Maintenance

The controller must be subjected to a safety check at regular intervals.

For the MULTI 6 24- and 36-zone controllers, it is recommended that the dust protection filter of the fan is cleaned occasionally. Depending on the operating hours and condition, the filter should be replaced as necessary.

The ventilation openings of the controller should also be checked regularly and cleaned of dirt.

This work should not be carried out by the user, but only by qualified service personnel.

No further maintenance work is required. In case of possible problems, please contact the manufacturer.

Fault displays



Thermocouple

Lights up if sensor is broken, and the actual value display shows “- - -”. If the automatic setter function (automatic mode) is active, the display alternates between “- - - -” and “- A - “. In case of incorrect connection, the display lights up and the actual value display shows the room temperature.



Temperature deviation

Flashes during the heating-up phase of the soft-start ramp. Remains on continually if the set limit temperatures are exceeded in either direction (see Changing setting values). The power supply is also switched off in the event of over-temperature.



Over-current

Lights up if the set maximum current is exceeded (see Changing setting values) or flashes if the load circuit is broken. The power supply is also switched off in the event of over-current.

Settings (factory settings)

Menu	Name	Function	Range	Factory setting
------	------	----------	-------	-----------------

The following functions can only be set globally for all zones

OVTEMP	Over-temperature alarm	Limit value, alarm output 1	0 - 50°C above setpoint value	10°C
UNTEMP	Under-temperature alarm	Limit value, alarm output 2	0 - 50°C below setpoint value	10°C
RMPEND	Ramp end	End temperature, Ramp 1	80 - 120°C	120°C
RMP T1	Gradient, ramp 1	Heating speed, ramp 1	2 - 10 seconds for 1°C	4 seconds
RMP T2	Gradient, ramp 2	Heating speed, ramp 2	2 - 10 seconds for 1°C	2 seconds
RMPPSE	Ramp pause	Pause between ramps 1 + 2	1 - 10 minutes	2 minutes
AUTO	Auto mode *	Automatic setting in case of sensor break	1 = On; 0 = Off	0 (Off)
TEMPDN	Temperature decrease function	Decrease in °C below setpoint value	10 – 200°C	50°C
TC TYP	Thermocouple	Fe-CuNi Type J or L	J or L	L
UNIT	Temperature unit	°C or °F	C or F	°C

The following functions can be set individually for each zone

TEMPUP	Temperature increase function	Temperature over setpoint value	5 - 60°C	20°C
UPTIME	Increase time	Duration of increase time	0 - 180 Sec.	120 Seconds
CURR	Over-current	Limit value	1 - 16 A	16 A
TMPMAX	Max. temperature	max. setpoint value	50 - 500°C	450°C
FW VER	Firmware-version	Shows actual version	--	--
PRESET	Factory setting	Resets all values to factory settings	--	--

* Auto mode operation is only possible after approx. 15 minutes of trouble-free operation!

Commissioning

The hotrunner controller HPS-C-MULTI 6 is designed for connection to a 3-phase power supply system (see Technical data). The controller is equipped with a CEE plug for this purpose. The main switch is located on the rear side of the controller, and disconnects the controller completely from the power supply. Connect the mould to the controller after checking the cabling carefully. If necessary, a connection can be made to the injection moulding machine by means of the alarm plug (accessory). Connect the power supply cable, and switch the controller on at the main switch.



Enter the setpoint value and ensure that unneeded control zones are switched off (see Entering setpoint value / Switching off).





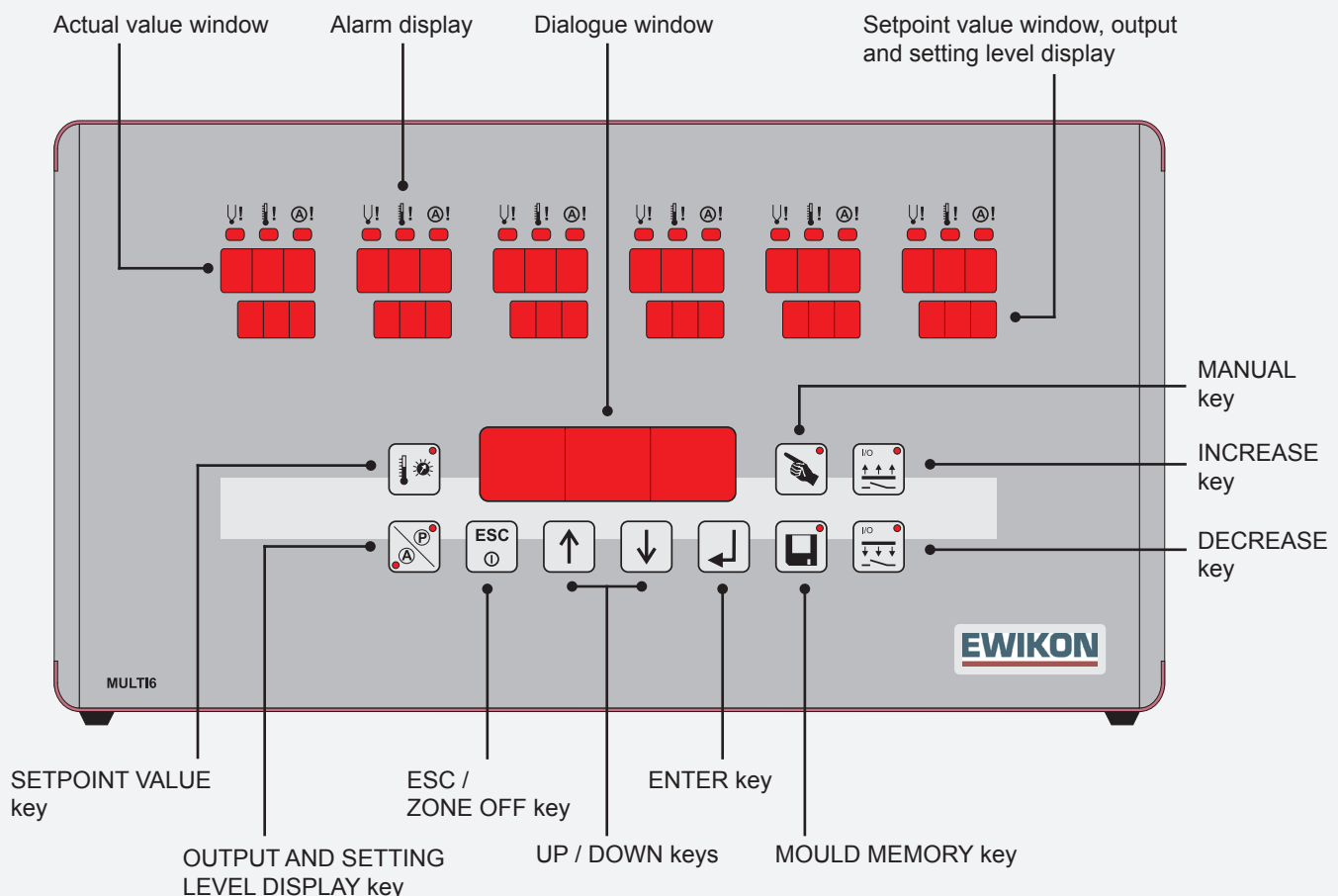

The controller now heats the mould evenly, and damp heating elements are dried out. The temperature deviation alarm display flashes for all active zones during this time (soft-start ramp). The actual value window displays the temperature in °C. The standby display appears for the deactivated zones.

After reaching the set target temperatures, production can be started with the factory settings. If faults occur during commissioning, the cause of the fault can be identified from the relevant displays of the individual zones (see Fault displays).

Front view





Entering setpoint value / Switching off control zones

Key	Command	Display
	Display setpoint value	The setpoint values are displayed, or OFF in the non-active zones. The key display lights up. The dialogue window shows Z ALL.
	Select zone	The dialogue window shows the selected zone. Z ALL for all zones.
	Confirm zone	The selected zone number flashes, or all in case of Z ALL. The dialogue window shows TEMP.
	Enter setpoint value,	Enter setpoint value using UP / DOWN keys.
	- Switch zone off	Pressing and holding the ESC / I key and again pressing the ESC / I key switches the selected zone off.
	- Switch zone on	Switches the selected zone on by pressing the ENTER key twice. The last entered setpoint value is reset.
	Confirm entry	Saves the set changes.
	Setpoint value display off	Key display off. Return to regulating operation. Setpoint value increases will be applied with 100% output performance!
	* Cancel without saving:	
	Cancel / Escape	Goes back one step in the programme without saving the current changes.









Function keys

Key display lights up when pressed (function on).

	Output display	The setpoint value windows of the active zones show the current performance output in % setting level or amperes. The key displays P or A light up.
	Increase active	Temperature will be increased briefly. (also externally via alarm plug)
	Decrease active	Temperature will be permanently decreased. (also externally via alarm plug)

* For mould memory and manual operation, see separate chapter.

Changing setting values

Key	Command	Display
 longer than 5 seconds	Change setting values	The dialogue window shows Z ALL, and the actual value windows show the zone numbers.
	Select zone	The selected zone is displayed in the dialogue window. Z ALL for all.
	Confirm zone	The dialogue window shows the first menu item, the selected zone number in the actual value window flashes.
	Select menu item	The current menu item is displayed in the dialogue window.
	Confirm menu item	The current setting values appear in the setpoint value window.
	Change value	Changed setting values are displayed. (Setting range, see Setting values / Factory setting)
	Save *	The changed setting values will be saved.
	Leave setting mode	Dialogue display off. Return to regulating operation.
* Cancel without saving:		
	Cancel / Escape	Goes back one step in the programme without changing the set values.

Soft-start ramp



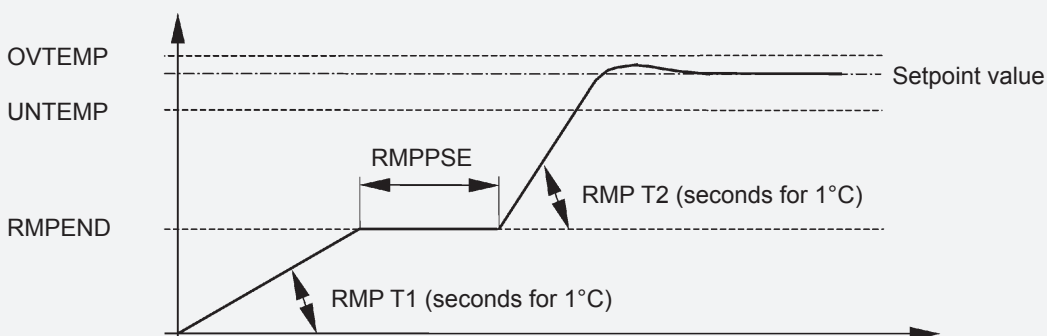



Active on: Restart, re-heating after decrease mode or after alarm message.



Manual mode





ATTENTION:

In this operating mode, the hotrunner is not regulated and will not be switched off in case of over-temperature. The hotrunner may therefore be overheated and severely damaged!

Key	Command	Display
	Manual mode	The setpoint value window displays oFF for all zones not in manual mode. The key display lights up.
	Select zone	The selected zone is displayed in the dialogue window.
	Confirm zone	The selected zone number flashes, The dialogue window shows PULS.
	Set setting level,	Set output performance in % setting level using the UP / DOWN keys
	- Manual mode OFF	Pressing and holding the ESC / ⓘ key and again pressing the ESC / ⓘ key switches setter operation of the current zone off.
	- Manual mode ON	Switches the selected zone on by pressing the ENTER key twice. The last set setting level is reset.
	Confirm entry	Saves the set changes.
	End entry	Key display off. Return to regulating operation. The setpoint value window of zones in manual mode alternate between the current display and PLS.
	* Cancel without saving:	
	Cancel / Escape	Goes back one step in the programme without saving the current changes.

*** The activated manual mode is reset by switching the controller off at the main switch!**

Mould memory

Key	Command	Display
	Call up memory function	The key display lights up. The zone numbers appear flashing in the actual value windows, and the current memory position is displayed in the dialogue memory.
	Select memory position	The selected memory position appears in the dialogue window.
	Confirm memory position	The display in the dialogue window changes to LOAD.
	Select function	With LOAD, the saved data are called up, with SAVE the set values are saved at the selected memory position.
	Confirm entry	Dialogue display. Return to regulating operation.

Replacing fuses



Work on the unit may be carried out only by qualified personnel. Disconnect from the power supply before opening the housing.

To replace fuses, remove the front panel attachments, take off the front panel and disconnect the plug connections. Pull out the relevant regulator card. Always replace fuses with others of the same type!

The regulator card are each configured for 6 zones. See below for configuration.

Reassemble in the reverse order.

Configuration of zones / regulator cards

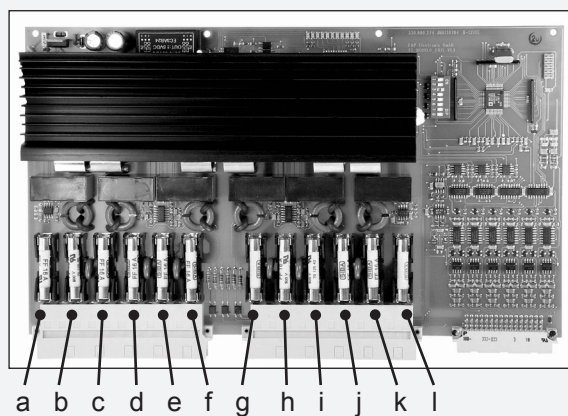
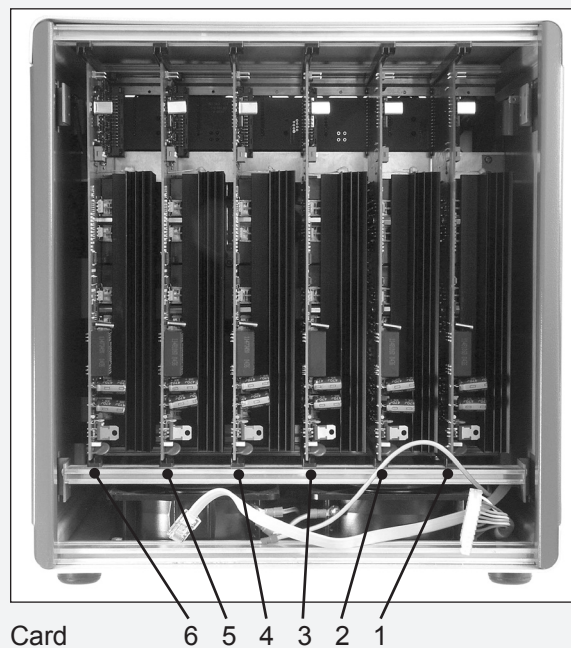
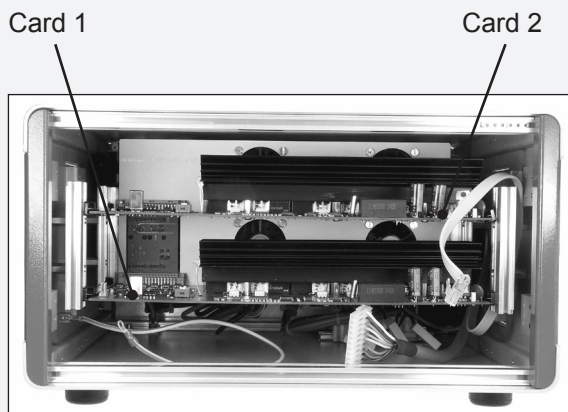

Fuses
Regulator card

Zone	Card	Fuse	Zone	Card	Fuse
1	1	a + b	19	4	a + b
2	1	c + d	20	4	c + d
3	1	e + f	21	4	e + f
4	1	g + h	22	4	g + h
5	1	i + j	23	4	i + j
6	1	k + l	24	4	k + l
7	2	a + b	25	5	a + b
8	2	c + d	26	5	c + d
9	2	e + f	27	5	e + f
10	2	g + h	28	5	g + h
11	2	i + j	29	5	i + j
12	2	k + l	30	5	k + l
13	3	a + b	31	6	a + b
14	3	c + d	32	6	c + d
15	3	e + f	33	6	e + f
16	3	g + h	34	6	g + h
17	3	i + j	35	6	i + j
18	3	k + l	36	6	k + l

Connections (to DIN 16765-A)

Load 16-pin

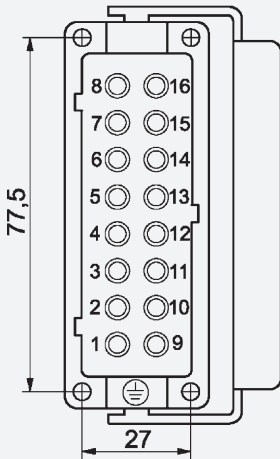

Zone	PIN
1	1 / 9
2	2 / 10
3	3 / 11
4	4 / 12
5	5 / 13
6	6 / 14
7*	7 / 15
8*	8 / 16

Earth conductor wired to housing!

Load 24-pin

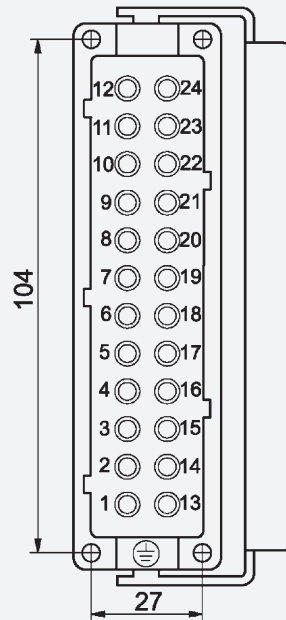

Zone	PIN
1, 13, 25	1 / 13
2, 14, 26	2 / 14
3, 15, 27	3 / 15
4, 16, 28	4 / 16
5, 17, 29	5 / 17
6, 18, 30	6 / 18
7, 19, 31	7 / 19
8, 20, 32	8 / 20
9, 21, 33	9 / 21
10, 22, 34	10 / 22
11, 23, 35	11 / 23
12, 24, 36	12 / 24

Earth conductor wired to housing!

Thermocouple 16-pin

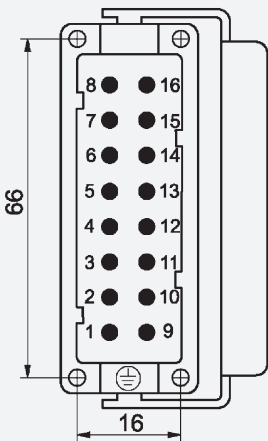

Zone	PIN
1	1 + / 9 -
2	2 + / 10 -
3	3 + / 11 -
4	4 + / 12 -
5	5 + / 13 -
6	6 + / 14 -
7*	7 + / 15 -
8*	8 + / 16 -

Earth conductor wired to housing!

Thermocouple 32-pin

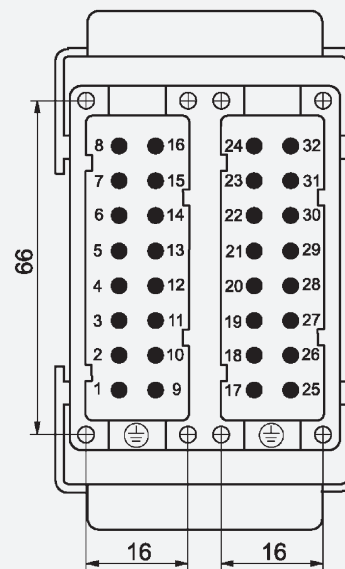

Zone	PIN
1, 13, 25	1 + / 9 -
2, 14, 26	2 + / 10 -
3, 15, 27	3 + / 11 -
4, 16, 28	4 + / 12 -
5, 17, 29	5 + / 13 -
6, 18, 30	6 + / 14 -
7, 19, 31	7 + / 15 -
8, 20, 32	8 + / 16 -
9, 21, 33	17 + / 25 -
10, 22, 34	18 + / 26 -
11, 23, 35	19 + / 27 -
12, 24, 36	20 + / 28 -

Earth conductor wired to housing!

* not wired for HPS-C-Multi 6, 6-zone

Connections

Alarm-plug 12-pin

(for matching plug and alarm cable, see accessories)

Alarm outputs: 1 = Over-temperature , 2 = Under-temperature

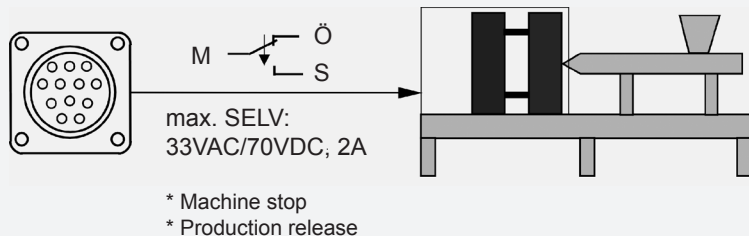

PIN / wire	Colour	Description
1	blue	Ö - Alarm 1 (OVTEMP)
2	pink	M - Alarm 1 (OVTEMP)
3	grey	S - Alarm 1 (OVTEMP)
6	red	S - Alarm 2 (UNTEMP)
7	black	M - Alarm 2 (UNTEMP)
8	violet	Ö - Alarm 2 (UNTEMP)

Alarm inputs: 1 = Temperature decrease, 2 = Temperature increase

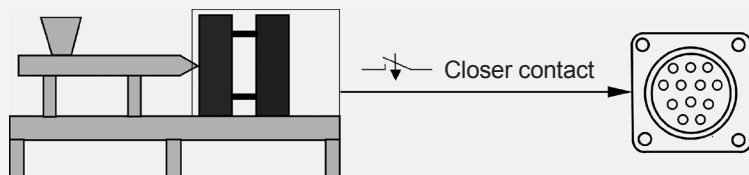

PIN / wire	Colours	Description
4 + 5	white + brown	E1 - Decrease
10 + 12	green + yellow	E2 - Increase

Technical data

Environmental conditions:

Operation in enclosed areas only, altitude up to 2000 m ASL, relative air humidity up to 80% at 30 °C, non-condensing, dirt level 2, operating temperature 10...40 °C, storage 0...50 °C

Housing:

Metal half-shell housing, IP20, protection class I

	Dimensions [mm] (WxHxD)	Weight [kg]
Multi 6 6-/12-zone	approx. 350 x 200 x 390	approx. 12
Multi 6 24-/36-zone	approx. 350 x 380 x 390	approx. 22

Power supply voltage:

4-wire 3-phase supply 230/400 VAC +/-10%, 50 Hz
Over-voltage category II, CEE 32 Ampere plug

Connection current:

max. 3 x 32 A

Plug connection:

Load and sensor separated; 16-, 24- or 32-pin (depending on zones)

Thermo-sensor:

Fe-CuNi Type J or L

Output:

max. 16A per Zone, contactless zero-switching

Regulating range:

100...500 °C, accuracy greater than 1 °C, with compatible accuracy of hot runner

EWIKON
Heißkanalsysteme GmbH
Siegener Straße 35
35066 Frankenberg
Tel: (+49) 64 51 / 50 10
Fax: (+49) 64 51 / 50 12 02
E-mail: info@ewikon.com
www.ewikon.com

Item number: 13831 Technical information subject to alteration. EWIKON 01/2006

EWIKON